

## VARIMETER Battery Symmetry Monitor BA 9054/331, BA 9054/332

Translation  
of the original instructions



0243311

### Your advantages

- Preventive maintenance
- For better productivity
- High repeat accuracy
- Large battery voltage ranges up to DC 500 V

### Features

- According to IEC/EN 60255-1
- To monitor for battery systems (emergency power supply)
- Measuring rang DC 0.12 ... 1.2 V, 0.2 ... 2 V or 1 ... 10 V
- Goldplated contacts to switch low loads
- With time delay 10 s
- LED indicators for operation and contact position
- Width: 45 mm

### BA 9054/331

- For battery voltages up to 300 V
- Without separately auxiliary voltage
- 2 changeover contacts

### BA 9054/332

- For battery voltages up to 500 V
- With separately auxiliary voltage
- 1 changeover contact

### Product Description

The battery symmetry monitor BA 9054/331 and BA 9054/332 of the VARIMETER series monitors battery systems with centre tapping for faults. Early detection of impending failures and preventive maintenance prevent costly damage and as a user you benefit from the operational safety and high availability of your system.

### Function Diagram

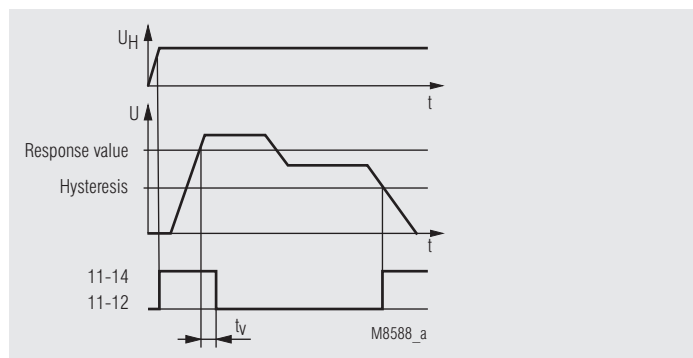

### Approvals and Markings



<sup>1)</sup> Approval not for all variants

### Applications

Monitoring of battery systems to find voltage inversions of single cells, internal short circuits and sulphating.

### Function

The middle connection of a Battery system is connected to terminal "M" of the BA 9054/331. If the two parts of the voltage differ more then the adjusted value for 10 s, the output relay trips. It trips also on broken wire on terminal "M".

The test button allows a test of the unit. It has to be pressed for at least 10 sec.

### Indicators

Green upper LED: On, when auxiliary supply connected  
Yellow lower LED: On, when output relay activated

### Circuit Diagrams

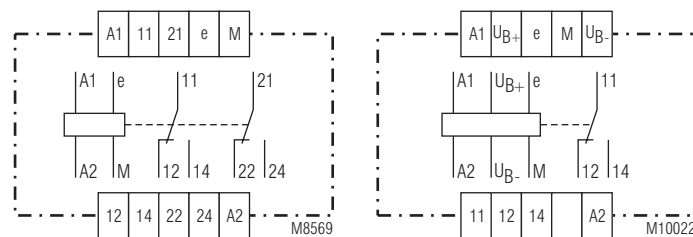

BA 9054/331

BA 9054/332

### Connection Terminals

Terminal designation	Signal description
A1, A2	Auxiliary voltage
$U_{B+}$ , $U_{B-}$	Batterie voltage
M	Middle tap of battery
e	Calibration reference
11, 12, 14	1 <sup>st</sup> Changeover contact
21, 22, 24	2 <sup>nd</sup> Changeover contact

### Notes

**Attention:** New batteries are not symmetric in the beginning. The battery monitor has to be readjusted after some time of operation. (see setting). The adjustment has to be verified by measuring the two parts of the voltage.



The gold plated contacts of the BA 9054 mean that this module is also suitable for switching small loads of 1 mVA ... 7 VA, 1 mW ... 7 W in the range 0.1 ... 60 V, 1 ... 300 mA. The contacts also permit the maximum switching current. However since the gold plating will be burnt off at this current level, the device is no longer suitable for switching small loads after this.

## Technical Data

### Input

<b>Sensitivity of tripping:</b> <b>(Measuring range):</b>	DC 0.12 ... 1.2 V absolute scale or, DC 0.2 ... 2 V absolute scale or DC 1 ... 10 V absolute scale
<b>Resetting value:</b>	98 % of operate value, fixed
<b>Repeat accuracy:</b>	≤ ± 0.5 %
<b>Time delay <math>t_v</math>:</b>	10 s
<b>Current middle connection</b> <b>(terminal M):</b>	Max. 12 µA (at 60 V or 220 V or 500 V)
<b>Principe de mesure:</b>	Arithmetic mean value
<b>Temperature influence:</b>	< 0.05 % / K

### Auxiliary Circuit

<b>BA 9054/331:</b> <b>Battery voltage =</b> <b>auxiliary voltage:</b>	DC 24 ... 60 V / DC 110 ... 220 V
<b>Voltage range:</b>	DC 19 ... 80 V / DC 60 ... 300 V
<b>BA 9054/332:</b> <b>Battery voltage (<math>U_B</math>):</b>	DC 10 ... 60 V, DC 200 ... 500 V
<b>Auxiliary voltage (A1/A2):</b>	DC 110 ... 220 V, AC 230 V
<b>Voltage range:</b>	0.8 ... 1.1 $U_H$
<b>Nominal consumption:</b>	Approx. 2.5 VA
<b>Nominal frequency:</b>	50 / 60 Hz
<b>Frequency range:</b>	± 5 %

### Output

<b>Contacts:</b> BA 9054/331:	2 changeover contacts
BA 9054/332:	1 changeover contacts
<b>Contact material:</b>	AgNi + 5 µm Au
<b>Switching of low loads:</b> (contact with 5 µm Au):	≥ 100 mV ≥ 1 mA
<b>Thermal current <math>I_{th}</math>:</b> BA 9054/331:	2 x 5 A
BA 9054/332:	1 x 5 A
<b>Switching capacity</b> to AC 15:	
NO contact:	2 A / AC 230 V IEC/EN 60947-5-1
NC contact:	1 A / AC 230 V IEC/EN 60947-5-1
To DC 13:	1 A / DC 24 V IEC/EN 60947-5-1
To DC:	8 A / DC 24 V or 0.3 A / DC 220 V
<b>Electrical life</b> to 3 A, AC 230 V cos φ = 1:	2 x 10 <sup>5</sup> switching cycl. IEC/EN 60947-5-1
<b>Short-circuit strength</b> <b>max. fuse rating:</b>	6 A gG / gL IEC/EN 60947-5-1
<b>Mechanical life:</b>	50 x 10 <sup>6</sup> switching cycles

### General Data

<b>Operating mode:</b>	Continuous operation
<b>Temperature range:</b> Operation:	- 40 ... + 60 °C
Storage:	- 40 ... + 70 °C
<b>Altitude:</b>	≤ 2000 m
<b>Clearance and creepage</b> <b>distances</b> Rated impulse voltage / pollution degree	
In-/output:	4 kV / 2 IEC 60664-1
<b>EMC</b> Electrostatic discharge:	8 kV (air) IEC/EN 61000-4-2
HF irradiation: 80 MHz ... 2.7 GHz:	10 V / m IEC/EN 61000-4-3
Fast transients:	4 kV IEC/EN 61000-4-4
Surge voltages between wires for power supply:	2 kV IEC/EN 61000-4-5
Between wire and ground:	4 kV IEC/EN 61000-4-5
HF wire guided:	10 V IEC/EN 61000-4-6
Interference suppression:	Limit value class B EN 55011

## Technical Data

### Degree of protection

Housing:	IP 40	IEC/EN 60529
Terminals:	IP 20	IEC/EN 60529

### Housing:

Thermoplastic with V0 behaviour  
according to UL subject 94

### Vibration resistance:

Amplitude 0.35 mm IEC/EN 60068-2-6  
frequency 10 ... 55 Hz

### Climate resistance:

40 / 060 / 04 IEC/EN 60068-1

### Terminal designation:

EN 50005

### Wire connection:

2 x 2.5 mm<sup>2</sup> solid or  
2 x 1.5 mm<sup>2</sup> stranded wire with sleeve  
DIN 46228-1/-2/-3/-4

### Wire fixing:

Plus-minus terminal screws M 3,5  
with self-lifting  
clamping piece IEC/EN 60999-1

Insulation of wires or

sleeve length:

10 mm

### Fixing torque:

0.8 Nm

### Mounting:

DIN rail

IEC/EN 60715

### Weight:

200 g

### Dimensions

**Width x height x depth:** 45 x 75 x 120 mm

### CCC-Daten

#### Thermal current $I_{th}$ :

5 A

#### Switching capacity

to AC 15: 2 A / AC 230 V IEC/EN 60947-5-1

To DC 13: 1 A / DC 24 V IEC/EN 60947-5-1

#### BA 9054/332:

#### Battery voltage ( $U_B$ ):

DC 10 ... 60 V



Technical data that is not stated in the CCC-Data, can be found  
in the technical data section..

## Standard Types

BA 9054/331 DC 0.12 ... 1.2 V DC 24 ... 60 V 10 s

- Article number: 0056172
- Measuring range: DC 0.12 ... 1.2 V
  - Auxiliary voltage: DC 24 ... 60 V
  - Time delay: 10 s
  - Width: 45 mm

BA 9054/331 DC 0.12 ... 1.2 V DC 110 ... 220 V 10 s

- Article number: 0056204
- Measuring range: DC 0.12 ... 1.2 V
  - Auxiliary voltage: DC 110 ... 220 V
  - Time delay: 10 s
  - Width: 45 mm

BA 9054/332 DC 0.12 ... 1.2 V DC 200 ... 500 V 10 s

- Article number: 0062251
- Measuring range: DC 0.12 ... 1.2 V
  - Auxiliary voltage: AC 230 V
  - Battery voltage: DC 200 ... 500 V
  - Time delay: 10 s
  - Width: 45 mm

## Ordering example

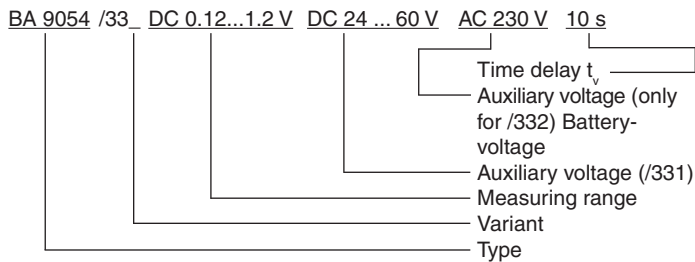

## Setting

- Connect the device as shown in application example.
- Connect nominal voltage (battery voltage) to A1/A2 (/331) e.g.  $U_B$  (/332).
- Set potentiometer for response value to min setting (0.12 V).
- Connect auxiliary  $U_H$  (/332) to A1, A2.
- Find the middle of the battery voltage with the potentiometers for symmetry "grob" and "fein" (tuning and fine tuning). Differences of block batteries can be adjusted up to 12 V. The correct setting is indicated by a green LED.
- Adjust potentiometer for response value to the required value. The device is now ready to use.

## Set-up Procedure

### Example 1

#### Symmetric battery

$U_1 = \frac{1}{2}$  battery voltage  
Adjust  $U_2$  with tuning and fine tuning potentiometer to 0 V.

### Example 2

#### 60 V battery set, combination of 12 V Block batteries

$U_1 = 36$  V  
Adjust  $U_2$  with tuning and fine tuning potentiometer to 0 V.

### Example 3

#### Non symmetric battery (compensation of battery tolerances)

$U_1 = \frac{1}{2}$  battery voltage + 200 mV  
Adjust  $U_2$  with tuning and fine tuning potentiometer to 0 V.

## Application Example

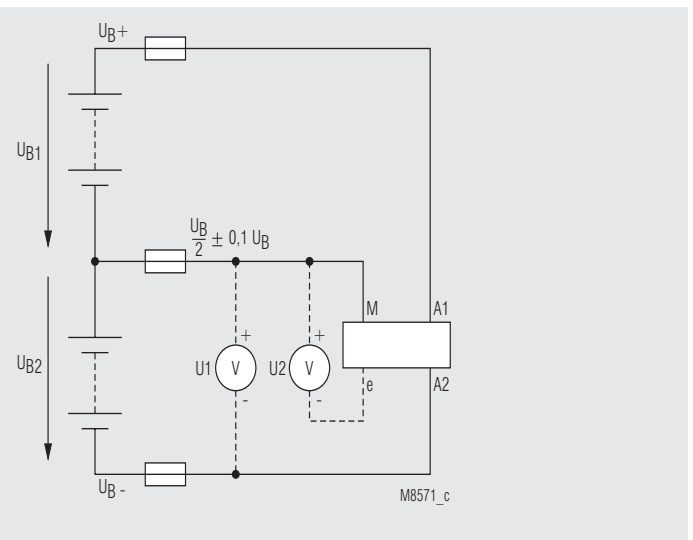

BA 9054/331

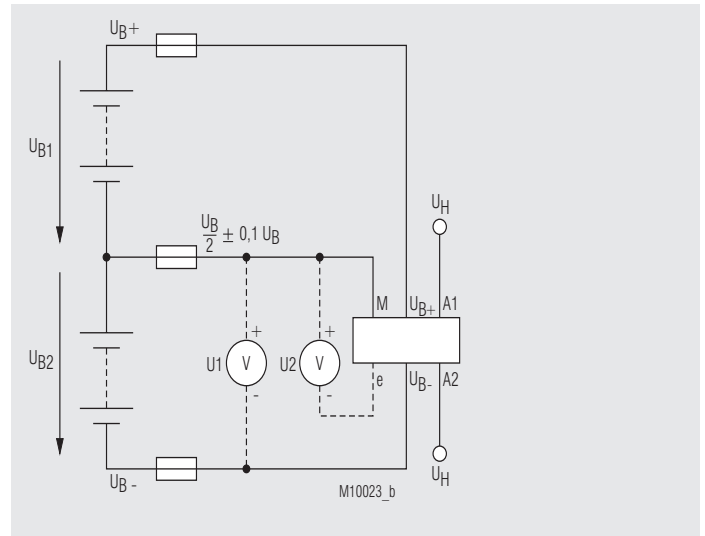

BA 9054/332

