



Installation use and maintenance



(Original instructions)





Safety Relay Module

SR E4 SAFETY RELAY MODULE

TABLE OF CONTENTS

OVERVIEW	3
OPERATING MODES	3
AUTOMATIC MODE.....	3
MANUAL MODE.....	4
SIMULTANEITY CHECK.....	4
ELECTRICAL CONNECTIONS.....	5
INSTRUCTIONS CONCERNING CONNECTION CABLES.....	5
PINOUT	6
CHECKLIST AFTER INSTALLATION	6
INPUT AND OUTPUT.....	7
THE RESTART COMMAND	7
K1K2 FEEDBACK INPUT.....	7
SYSTEM STATUS OUTPUT	7
CHARACTERISTICS OF THE OUTPUT CIRCUIT	8
USE OF K1 AND K2 AUXILIARY CONTACT ELEMENTS.....	8
STATUS INDICATORS.....	9
NORMAL OPERATION	9
FAULT DIAGNOSIS.....	9
TECHNICAL DATA	10
DIMENSIONS.....	11
INDICATIONS AND INFORMATION FOR ENVIRONMENTAL PROTECTION	12
WARRANTY.....	13
EC DECLARATION OF CONFORMITY	14
UKCA DECLARATION OF CONFORMITY	15

 This symbol indicates an important personal safety warning. Failure to comply with the warning may result in very high risk for exposed personnel.

 This symbol indicates an important warning.

OVERVIEW

The SR E4 Safety Relay is able to monitor two inputs coming from safety gate, safety guard or similar (two channels electromechanical safety switch).

The SR E4 module main features are the following:

- Input for Safety gate, Safety guard
- Restart manual or automatic selectable
- 2 N.O. outputs with guided contact safety relays
- 1 system monitor PNP output
- 1 external contactors feedback input

OPERATING MODES

AUTOMATIC MODE

 This mode is activated connecting the RESTART (terminal 4) directly to 24VDC.

In **Automatic Mode**, the outputs of the safety module follow the status of the safety relay inputs (terminals 7, 8) coming from the safety guard:

- with the safety relay inputs active, the relay outputs of the safety module are active.
- with the safety relay inputs not active, the relay outputs of the safety module are de-activated.

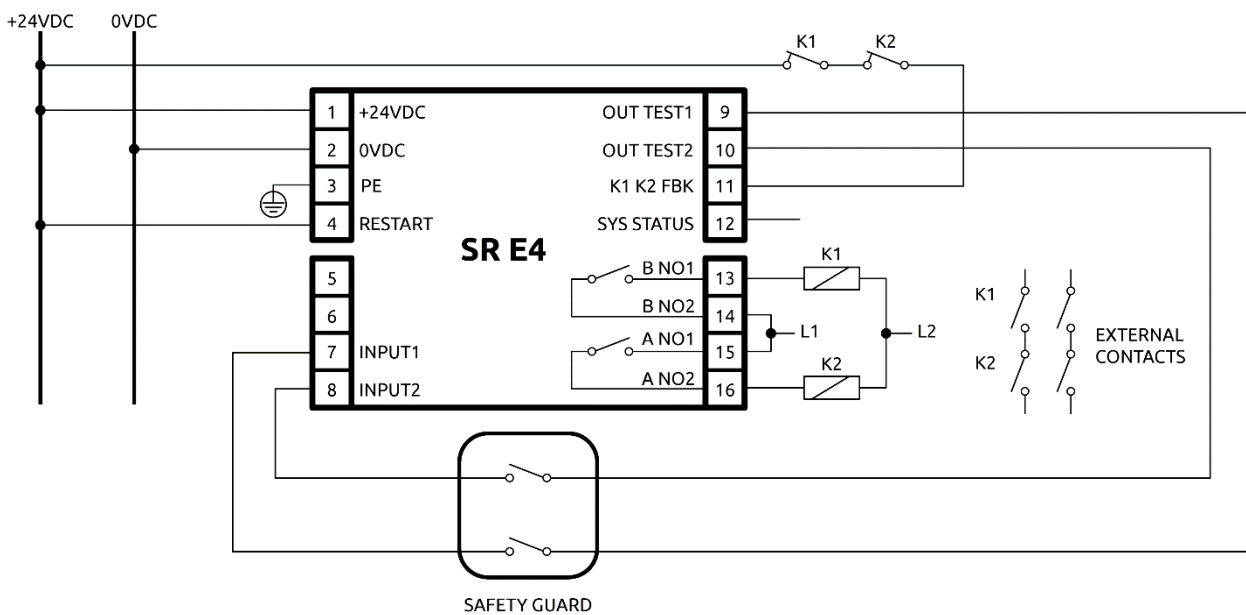

Figure 1 – Automatic operation with K1 K2 relays

- Use in manual mode (start/restart interlock activated) is mandatory in case the safety device controls an access protecting a danger zone and once a person has passed through the opening, he/she may remain in the danger zone without being detected. Failure to comply with this rule may result in very serious risks for the persons exposed.
- When the K1-1 and K2-1 N.C. control contacts are not used (or no control is provided) it is mandatory to connect the terminal 11 (K1 K2 FBK) to terminal 12 (SYS STATUS).

MANUAL MODE

With **Manual Mode**, the outputs of the safety relay are activated only if the safety relay inputs (terminals 7, 8) are both active and after sending the RESTART signal to the relay using the push-button or by means of a specific command on the RESTART input (terminal 4) (please refer to "The RESTART command" section).

- The RESTART command is active with a voltage of 24VDC.
- If the RESTART signal is permanently connected to 24VDC the safety module relay works in automatic restart mode.

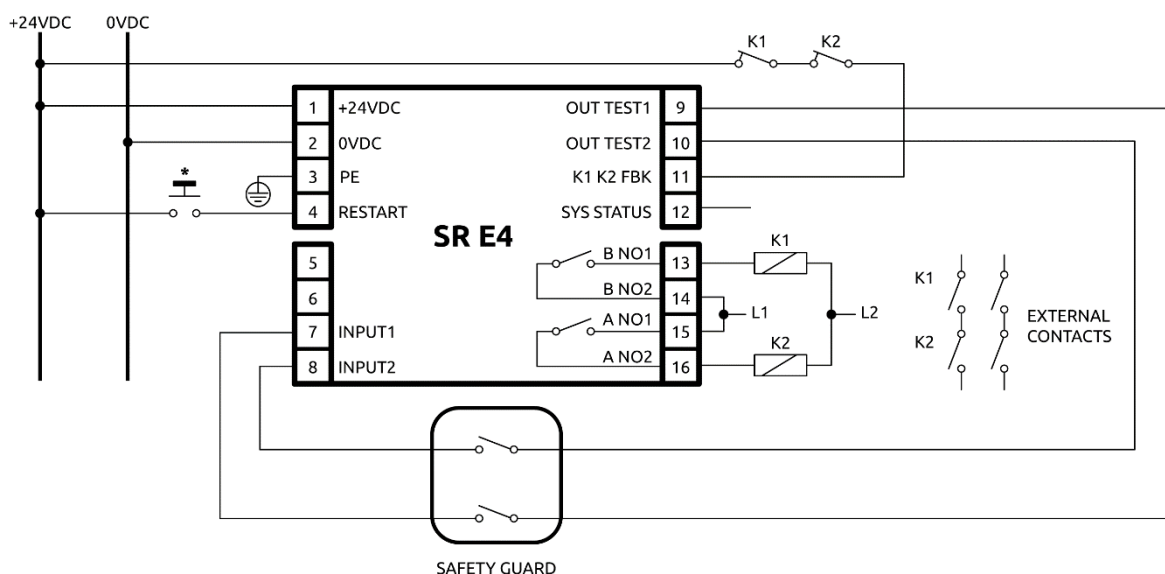

* When pin 4 is permanently connected to 24VDC the module works in automatic restart mode

Figure 2 – Manual operation with K1 K2 relays

SIMULTANEITY CHECK

The SR E4 Safety Relay module is able to monitor two inputs coming from a safety gate, safety guard or similar (two channels electromechanical safety switch).

Short circuit between the two channels or between the channels and 24VDC are detected by means of the OUT TEST1, OUT TEST2 signals generated by the safety relay.

Between the two channels a simultaneity check is performed (within 1 sec).

- If the simultaneity is not respected, the system remains in OFF with an alternate flashing of the LEDs IN1 - IN2/FAIL. To reactivate the outputs, it is necessary to open again and close INPUT1 and INPUT2 (respecting the simultaneity).

ELECTRICAL CONNECTIONS



Figure 3

SR E4 is provided with terminal blocks for the electrical connections.

The unit provides 16 terminals.

→ Terminal tightening torque: 5...7lb-in (0,6...0,7 Nm).

- Install SR E4 in an enclosure with a protection class of at least IP54.
- Connect the safety relay module when it is not powered.
- The supply voltage to the units must be $24 \pm 20\%$ VDC; PELV (in compliance with the standard EN 60204-1 (Chapter 6.4)).
- Do not use the SR E4 to supply external devices.
- The same ground connection (0VDC) must be used for all system components.

INSTRUCTIONS CONCERNING CONNECTION CABLES

- Wire size range: AWG 12...30, (solid/stranded) (UL).
- Use 60/75°C copper (Cu) conductor only.
- We recommend the use of separate power supplies for the safety controller and for other electrical power equipment (electric motors, inverters, frequency converters) or other sources of disturbance.
- Cables used for connections longer than 50m must have a cross-section of at least 1mm^2 (AWG16).

PINOUT

TERMINAL NUMBER	SIGNAL NAME	TYPE OF SIGNAL	DESCRIPTION
1	24VDC	-	Power supply 24VDC
2	0VDC	-	Power supply 0VDC
3	PE	-	Ground connection
4	RESTART	Input	Restart command
5	-	-	-
6	-	-	-
7	INPUT1	Input	Mechanical switch Input 1
8	INPUT2	Input	Mechanical switch Input 2
9	OUT TEST1	Output	Test output 1 for mechanical switch
10	OUT TEST2	Output	Test output 2 for mechanical switch
11	K1 K2 FBK	Input	Feedback external contactors K1K2
12	SYS STATUS	Output	Output status
13	B NO1	Output	Safety relay B, contact 1 (N.O.)
14	B NO2	Output	Safety relay B, contact 2 (N.O.)
15	A NO1	Output	Safety relay A, contact 1 (N.O.)
16	A NO2	Output	Safety relay A, contact 2 (N.O.)

Table 1

CHECKLIST AFTER INSTALLATION

The SR E4 Safety Relay Module is able to detect in real time the faults.

To guarantee the system perfect operation perform the following checks at start up and at least every year:

OPERATION / CONTROL	COMPLETE
1. Verify that all the cables are correctly inserted and the terminal blocks well screwed.	<input type="checkbox"/>
2. Verify the correct fixing of SR E4 to the Omega rail.	<input type="checkbox"/>
3. Verify that all the LEDs (indicators) light on correctly.	<input type="checkbox"/>
4. Verify the positioning of all the actuators connected to SR E4.	<input type="checkbox"/>
5. Verify that all the external indicators (lamps) work properly.	<input type="checkbox"/>

Table 2

INPUT AND OUTPUT

THE RESTART COMMAND

The RESTART command allows SR E4 to manage Manual operation.

- ⚠ The RESTART command must be installed outside the danger area in a position where the danger area and the entire work area concerned are clearly visible.
- ⚠ It must not be possible to reach the control from inside the danger area.

- ➔ The RESTART command must be sent to SR E4 connecting terminal 4 to 24VDC.
- ➔ The contact used for the RESTART command must be able to switch a voltage of 24VDC and a current of 10mA (guaranteeing a closing time >100ms).
- ➔ The whole SYSTEM RESET TIME is obtained adding the reset time of any external contactors K1-K2 to the reset time of SR E4.

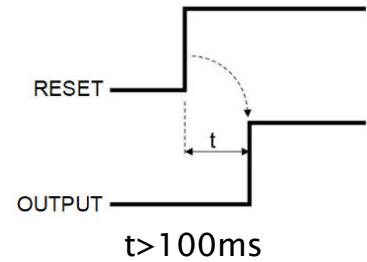

K1K2 FEEDBACK INPUT

Using the K1 and K2 auxiliary safety contactors with guided contact safety type, it is necessary to connect the +24VDC to the **K1 K2 FBK** through the series of the K1-1 and K2-1 N.C. control contacts.

- ➔ The control of the correct switching of K1 and K2 is performed with a delay of 300ms.
- ⚠ If the application requires it, the response time of the external contactors must be verified by an additional device.
- ⚠ When the K1-1 and K2-1 N.C. control contacts are not used (or no control is provided) it is mandatory to connect the terminal 11 (K1K2 FEEDBACK) to terminal 12 (SYSTEM STATUS).

SYSTEM STATUS OUTPUT

The SYSTEM STATUS output reports exactly the output safety relays condition:

- When the output relays are opened, the SYSTEM STATUS reports 0VDC.
- When the output relays are closed, the SYSTEM STATUS reports +24VDC.

CHARACTERISTICS OF THE OUTPUT CIRCUIT

For the output circuit, the safety relay module uses two guided contact safety relays. These relays are rated by the manufacturer for voltage and current values above those indicated in the technical data; however, to assure correct insulation and to avoid damage or premature aging, protect each output line with an appropriate fuse (depending on the load). Check that load characteristics comply with the indications given in the table below.

Minimum switching voltage	18 VDC
Minimum switching current	20 mA
Maximum switching voltage	250 VAC
Maximum switching current	6A(AC) / 6A(DC)

USE OF K1 AND K2 AUXILIARY CONTACT ELEMENTS.

For loads with higher voltage and current characteristics than those indicated in the table above, use of auxiliary external relays or contactors suitable for the load to be controlled is recommended.

- The K1 and K2 auxiliary contactors or relays must be of the guided contact safety type.
- Referring to the table below, pay particular attention to the configuration of the control contacts on terminal 11 and that of the contacts of use.

	Auxiliary Relay K1	Auxiliary Relay K2
Control contacts	K1-1 normally closed	K2-1 normally closed
Use contacts	K1-2 normally open	K2-2 normally open

- Control contacts K1-1 and K2-1 (terminal 11) must be able to switch a current of 10mA and a voltage of 24VDC.

STATUS INDICATORS

NORMAL OPERATION

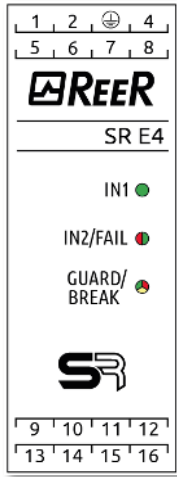

LED	COLOR	STATUS/COLOR	CONDITION
IN1	Green	ON	Input contact1 CLOSED
		OFF	Input contact1 OPEN
IN2/ FAIL	Red Green	RED	Fault detected
		GREEN	Input contact2 CLOSED
		OFF	Input contact2 OPEN
GUARD/ BREAK	Green Red Yellow	RED	Output relays opened
		RED blinking	The number of blinks show the type of FAIL (only with red FAIL led ON)
		GREEN	Output relays closed
		YELLOW	Input ON, Output OFF and waiting for Restart
IN1/IN2	Green	Blinking alternately	Wrong simultaneity check detected

Table 3

- ➔ The max Simultaneity check value will be **1 sec.**
- ➔ Please refer to the *"SIMULTANEITY CHECK"* section for a detailed explanation of this check.
- ➔ Please refer to the *"FAULT DIAGNOSIS"* section for a detailed explanation of the detected fault.

FAULT DIAGNOSIS

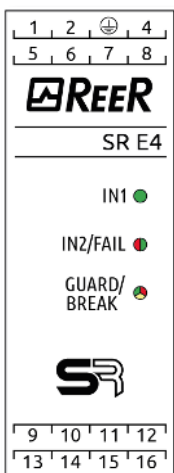

		LED		MEANING
IN1	IN2/FAIL	GUARD/BREAK (RED led pulses)		
OFF	RED	(2 pulses)		▪ Possible fault of Microcontroller board
OFF	RED	(3 pulses)		▪ Internal relays fault
OFF	RED	(4 pulses)		▪ K1K2 external relays fault
OFF	RED	(5 pulses)		▪ User configuration failure
OFF	RED	(6 pulses)		▪ User configuration changed without system restart
OFF	RED	(7 pulses)		▪ Possible overload or ▪ SYSTEM STATUS connection error

Table 4

TECHNICAL DATA

SAFETY DATA	VALUE	STANDARD
Safety level	SIL 3	EN 61508:2010
	SILCL 3	EN 62061:2005 / A2:2015
	Cat.4	EN ISO 13849-1: 2015
Device lifetime	20 years	EN ISO 13849-1: 2015
Certifications	cULus, TÜV	

Load	Number of Commutations	PFHd *	DCavg #	MTTFd # (years)	PL #	CCF #
2A@230Vac	1 every 30s	1,73E-07	99,00%	25,05	d	80%
	1 every min	8,90E-08	99,00%	46,65	e	80%
	1 every hour	6,60E-09	98,98%	306,21	e	80%
	1 every day	5,29E-09	98,97%	335,91	e	80%
0,5A@24VDC	1 every 30s	3,41E-07	99,00%	13,01	d	80%
	1 every min	1,73E-07	99,00%	25,05	d	80%
	1 every hour	7,99E-09	98,98%	279,82	e	80%
	1 every day	5,38E-09	98,97%	333,75	e	80%

* EN 61508:2010, EN 62061:2005/A2:2015; # EN ISO 13849-1:2015

ELECTRICAL PARAMETERS	VALUE
Power supply	24 ± 20% VDC; PELV
Rated impulse between PELV and relay contacts	6 kV
Power requirement	3W max
Protection	Overload protected STATUS output
INPUT DATA	VALUE
Input number/data (type 3)	3 / according to standard EN61131-2, type 3
Input current	Typical 4.3mA
Input voltage	0VDC...30VDC
Input number/data (type 2)	1 / according to standard EN61131-2, type 2
Input current	Typical 10mA
Input voltage	0VDC...30VDC
Number of EDM input	1 N.C. contact
EDM Response time	300ms
OUTPUT DATA	VALUE
Output test (number/data)	2 / 100mA@24VDC
System Status Output	100mA@24VDC
Number of safety output	2 N.O. contacts
Type	Relays with forced guided contacts
Max switching voltage	250VAC, 125 VDC, Overvoltage Category III
Max switching current	6A (AC), 6A (DC)
Max switching power	1500VA, 180W (85W if load voltage >30Vdc)
Max Response time	20ms
Mechanical service life	10 x 10E6
Electrical service life AC1 at 360 switchings/h	> 10E5
CONNECTIONS / OPERATION	VALUE
Operating modes	Automatic or Manual selectable
Connections	16 Terminal blocks with protection against reversal of polarity
Status indicators	Led: Input status – Output status – Fail
Max. length of connections	100m
Operating temperature	-30...55°C
Max surrounding air temperature	55°C
Storage temperature	-30...70°C
Relative humidity	10%...95%
Maximum operating altitude	2000m
Vibration resistance (CEI EN 60068-2-6:2009)	+/- 1.5 mm 9...200 Hz
Bump resistance (CEI EN 60068-2-27:2012)	15 g (6 ms half-sine)

ENCLOSURE DATA	VALUE
Description	Electronic housing 16 pole, with locking latch mounting
Enclosure protection rating	IP 20
Terminal block protection rating	IP 2X
Fastening	Fast attachment to rail according to CEI EN 60715
Dimensions (h x w x d)	99mm x 22,6mm x 113,5mm
Weight	150g

DIMENSIONS

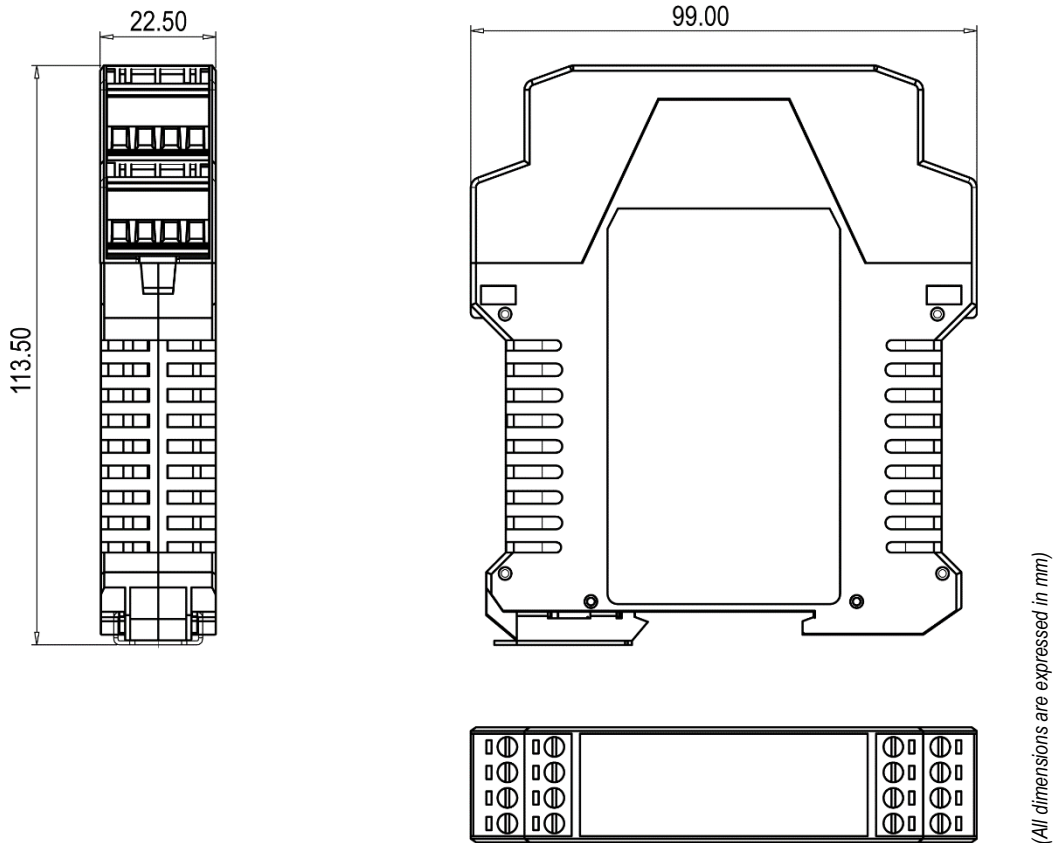

Figure 4

INDICATIONS AND INFORMATION FOR ENVIRONMENTAL PROTECTION

Dispose of the product in an eco-compatible manner and in accordance with national legislation.

**For Countries in the European Union:**

Pursuant to the Directive no. 2012/19/EU on waste electrical and electronic equipment (WEEE).

The crossed out wheellie-bin symbol on the equipment or its packaging means that when the product reaches the end of its useful life it must be collected separately from other waste.

Proper separate collection of the discarded equipment for later environment-friendly recycling, processing, and disposal, helps to avoid any negative impact on the environment and health and encourages re-use and recycling of the materials the equipment is made of.

In each individual Member State of the European Union this product is required to be disposed of in accordance with Directive 2012/19/EU as implemented in the Member State where the product is disposed of.

For further information please contact Reer or your local dealer.

WARRANTY

ReeR warrants that all its SR E4 units shall be free from defects in material or workmanship for a period of 12 (twelve) months from the date of shipment. This warranty applies to the products under normal conditions of use.

If the product proves to be defective during the warranty period, ReeR will repair or replace any faulty parts without any charge for material or labour.

ReeR S.p.A. may, at its discretion, replace the defective equipment with the same type of equipment or with equipment having the same characteristics, rather than repair it.



This warranty is subject to the conditions listed below:

- The customer must inform ReeR of the fault within twelve months from the date of delivery of the product.
- The equipment and all components must be in the condition as they were at the time of delivery by ReeR.
- The fault or defect must not be caused either directly or indirectly by:
 - Improper use;
 - Failure to comply with the instructions for use;
 - Carelessness, misuse, incorrect maintenance;
 - Repairs, modifications, adaptations not performed by ReeR, tampering, etc.;
 - Accidents or collisions (also during transportation and as a result of force majeure);
 - Other causes for which ReeR cannot be held liable.

The defective equipment must be delivered or shipped to ReeR's works to be repaired: the warranty does not cover costs of transport or the risk of damage to or loss of the equipment during shipment, which shall be borne by the customer.

All products and components that are replaced become the property of ReeR.

ReeR shall not be held liable under any other warranties or rights except for those expressly indicated above. ReeR shall not therefore accept claims to pay damages for expenses, interruption of work or other factors or circumstances in any way related to failure of the product or any parts thereof.

-  Precise, complete compliance with all standards, instructions, and warnings in the present SR E4 handbook is essential for the correct operation of SR E4 safety relay.
-  ReeR therefore declines any responsibility for all and anything resulting from failure to comply with all or some of the aforesaid instructions.

Characteristics are subject to change without prior notice. No part of this document may be reproduced unless authorised by ReeR.

EC DECLARATION OF CONFORMITY



Dichiarazione CE di conformità
EC declaration of conformity

Torino, 19/09/2022

REER SpA
via Carcano 32
10153 – Torino
Italy

dichiara che i moduli di sicurezza **SR SELECT / SR ONE / SR ONE M / SR T / SR E4 / SR E4C** sono Dispositivi Elettrosensibili di Sicurezza (ESPE) di:

- **Tipo 4** (secondo la Norma **EN IEC 61496-1:2020**)
- **SIL 3** (secondo la Norma **EN 61508: 2010**)
- **SILCL 3** (secondo la Norma **EN 62061 + A2:2015**)
- **PL e** (secondo la Norma **EN ISO 13849-1:2015**)

declares that the safety interface **SR SELECT / SR ONE / SR ONE M / SR T / SR E4 / SR E4C** are Electro-Sensitive Safety Devices (ESPE) of:

- **Type 4** (according the Standard **EN IEC 61496-1:2020**)
- **SIL 3** (according the Standard **EN 61508:2010**)
- **SILCL 3** (according the Standard **EN 62061 + A2:2015**)
- **PL e** (according the Standard **EN ISO 13849-1:2015**)

realizzati in conformità alle seguenti Direttive Europee:
complying with the following European Directives:

- **2006/42/EC** "Direttiva Macchine"
"Machine Directive"
- **2011/65/EU** "RoHS – Linea Guida"
"RoHS – Guideline "
- **2014/30/EU** "Direttiva Compatibilità Elettromagnetica"
"Electromagnetic Compatibility Directive"

e alle seguenti Norme: /and to the following Standards:

- **EN 55032: 2015**
- **EN IEC 63000: 2018**

e sono identici all'esemplare esaminato ed approvato con esame di tipo CE da:
and are identical to the specimen examined and approved with a CE - type approval by:

TÜV SÜD Product Service GmbH – Zertifizierstelle – Ridlerstraße 65 – 80339 – München – Germany
N.B. number: 0123 - Certificate number: Z10 024820 0085 Rev. 01

Responsabile per la documentazione tecnica:
Responsible person for technical documentation:

Carlo Pautasso

Carlo Pautasso
Direttore Tecnico
Technical Director

Simone Scaravelli
Amministratore Delegato
Managing Director

UKCA DECLARATION OF CONFORMITY

Reer declares that SR E4 Safety Relay module complies with following UK legislation:

- S.I. 2008 No. 1597 - The Supply of Machinery (Safety) Regulations
- S.I. 2016 No. 1101 - Electrical Equipment (Safety) Regulations
- S.I. 2016 No. 1091 - Electromagnetic Compatibility Regulations
- S.I. 2012 No. 3032 - The Restriction of the Use of Certain Hazardous Substances in Electrical and Electronic Equipment Regulations

→ Please refer to the link <https://www.reersafety.com/certifications> to download the complete UKCA Declaration of Conformity.



Via Carcano, 32
10153 Torino, Italy
T +39 011 248 2215
F +39 011 859 867
www.reersafety.com
info@reer.it

