

A) CONTENUTO IMBALLO - PACKAGE CONTENTS - CONTENU DE L'EMBALLAGE - PACKUNGSINHALT - CONTENIDO DEL EMBALAJE

- (I) SR E4 Modulo di sicurezza a relè / La presente guida di installazione
- (EN) SR E4 Safety Relay module / This quick installation guide
- (FR) SR E4 Module Relais de sécurité / Le présent guide d'installation
- (D) SR E4 Sicherheitsrelais-Modul / Die vorliegende Installierungsanleitung
- (E) SR E4 Módulo de relé de seguridad / La presente guía de instalación

B) MONTAGGIO MECCANICO - MECHANICAL ASSEMBLY - MONTAGE MECANIQUE - BEFESTIGUNG - MONTAJE MECÁNICO

- ⚠ **Le operazioni che seguono devono essere effettuate in assenza di alimentazione.**
- (I) Fissare il modulo alla barra DIN premendolo delicatamente fino a sentire lo scatto del bloccaggio. Per rimuovere un modulo è necessario tirare verso il basso (utilizzando un cacciavite) il gancio di arresto posto sul retro del modulo; sollevare quindi il modulo dal basso e tirare.
- ⚠ **Do not apply power supply before carry out the following operations.**
- (EN) Fasten the module to the DIN rail. Press the unit gently until you feel it snap into place. To remove the module, use a screwdriver to pull down the locking latch on the back of the unit; then lift the unit upwards and pull.
- ⚠ **Les opérations suivantes doivent être effectuées en l'absence d'alimentation.**
- (FR) Montez le module sur la barre DIN en appuyant doucement sur le module jusqu'à ce que vous entendiez le verrouillage du module. Pour démonter un module, vous devez tirer vers le bas (à l'aide d'un tournevis) sur le crochet de retenue situé à l'arrière du module, puis soulever le module par le bas et tirer.
- ⚠ **Die im Anschluss beschriebenen Vorgänge müssen bei unterbrochener Stromversorgung ausgeführt werden.**
- (D) Befestigen Sie das Modul auf der DIN-Hutschiene, indem Sie es vorsichtig nach unten drücken, bis es einrastet. Um ein Modul zu entfernen, müssen Sie (mit einem Schraubendreher) den Haltehook auf der Rückseite des Moduls nach unten ziehen, dann das Modul von unten anheben und abziehen.
- ⚠ **Las siguientes operaciones se deben llevar a cabo con la alimentación cortada.**
- (E) Enganche el módulo a la barra DIN presionandolo delicadamente hasta que escuche el bloqueo del módulo. Para retirar un módulo debe tirar hacia abajo (con un destornillador) del gancho de retención en la parte posterior del módulo, luego levante el módulo por la parte inferior y tire.

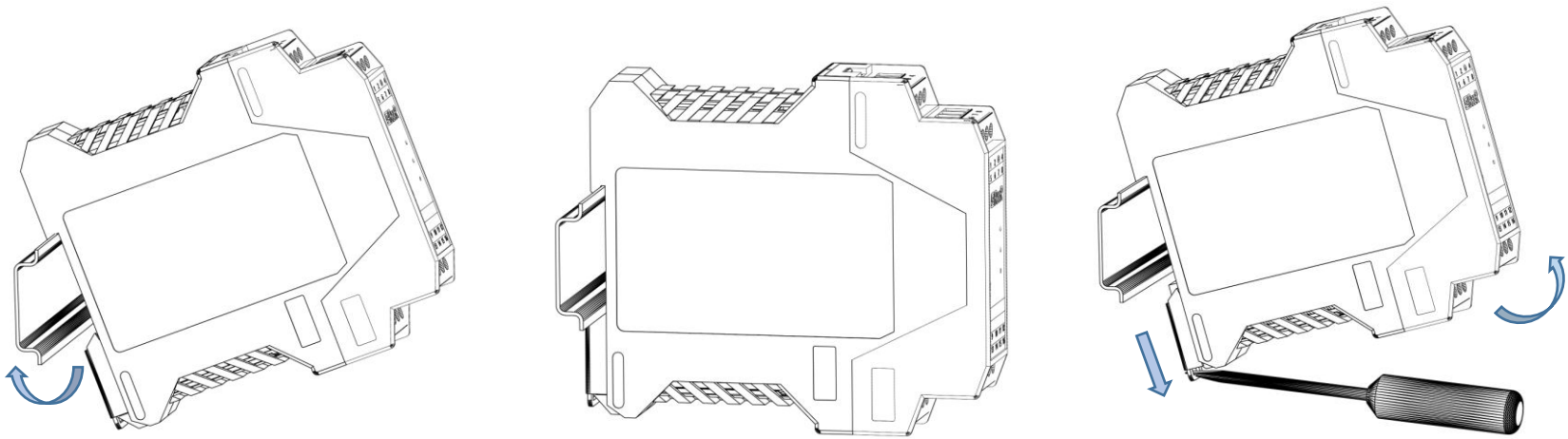

Figure 1 – Montaggio-smontaggio meccanico / Mechanical assembly-disassembly

C) MORSETTIERE DEL MODULO / TERMINAL BLOCKS OF MODULE / BORNIERES DU MODULE / ANSCHLUSSKLEMMEN DES MODULS / TERMINALES DEL MÓDULO



Figure 2

TERMINAL NUMBER	SIGNAL NAME	TYPE OF SIGNAL	DESCRIPTION
1	24VDC	-	Power supply 24VDC
2	0VDC	-	Power supply 0VDC
3	PE	-	Ground connection
4	RESTART	Input	Restart command *
5	-	-	-
6	-	-	-
7	INPUT1	Input	Mechanical switch Input 1
8	INPUT2	Input	Mechanical switch Input 2
9	OUT TEST1	Output	Test output 1 for mechanical switch
10	OUT TEST2	Output	Test output 2 for mechanical switch
11	K1 K2 FBK	Input	Feedback external contactors K1K2 **
12	SYS STATUS	Output	Output status
13	B NO1	Output	Safety relay B, contact 1 (N.O.)
14	B NO2	Output	Safety relay B, contact 2 (N.O.)
15	A NO1	Output	Safety relay A, contact 1 (N.O.)
16	A NO2	Output	Safety relay A, contact 2 (N.O.)

* IF THE RESTART SIGNAL IS PERMANENTLY CONNECTED TO 24VDC THE SAFETY MODULE RELAY WORKS IN AUTOMATIC RESTART MODE
 ** WHEN THE K1 1 AND K2 1 N.C. CONTROL CONTACTS ARE NOT USED (OR NO CONTROL IS PROVIDED) IT IS MANDATORY TO CONNECT THE TERMINAL 11 (K1 K2 FBK) TO TERMINAL 12 (SYS STATUS)

Table 1 – Morsettiere / Terminal blocks

D) SEGNALAZIONI / STATUS INDICATORS / INDICATEURS / STATUSANZEIGEN / INDICADORES DE ESTADO

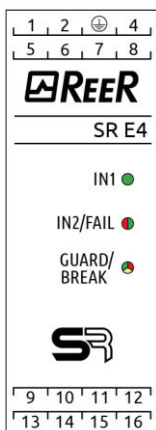

Figure 3

LED	COLOR	STATUS/COLOR	CONDITION
IN1	Green	ON	Input contact1 CLOSED
		OFF	Input contact1 OPEN
IN2/ FAIL	Red Green	RED	Fault detected *
		GREEN	Input contact2 CLOSED
		OFF	Input contact2 OPEN
GUARD/ BREAK	Green Red Yellow	RED	Output relays opened
		RED blinking	The number of blinks show the type of FAIL (only with red FAIL led ON) *
		GREEN	Output relays closed
IN1/IN2	Green	YELLOW	Input ON, Output OFF and waiting for Restart
		Blinking alternately	Wrong simultaneity check detected

* REFER TO THE "FAULT DIAGNOSIS" SECTION IN THE TECHNICAL MANUAL TO HAVE A DETAILED EXPLANATION OF THE POSSIBLE FAULT

Table 2 – Segnalazioni / Status Indicators



Example of connection of the SR E4 in AUTOMATIC operation with K1 K2 relays

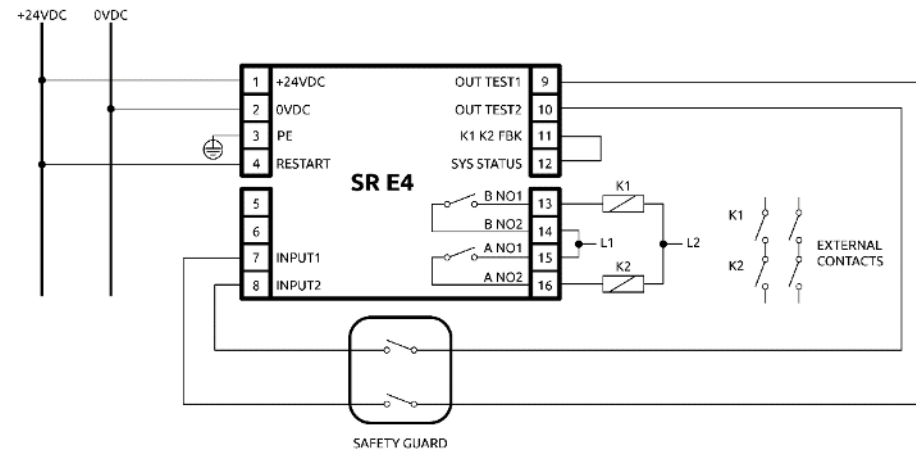
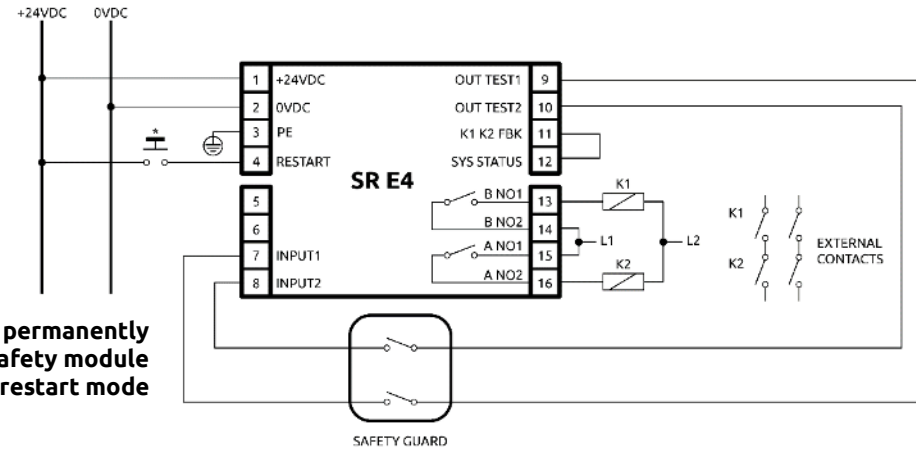

Figure 4

Example of connection of the SR E4 in MANUAL operation with K1 K2 relays



* If the RESTART signal is permanently connected to 24VDC the safety module relay works in automatic restart mode

Figure 5

Example of connection of the SR E4 in AUTOMATIC operation with K1 K2 relays and FBK K1 K2

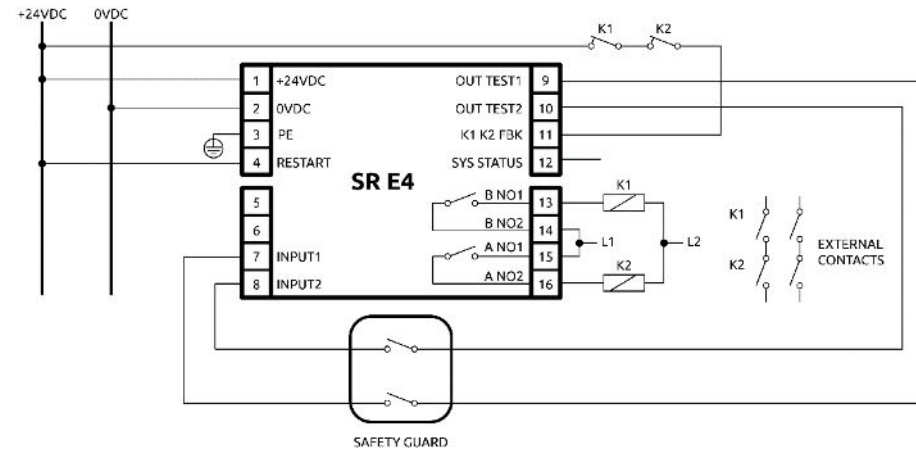
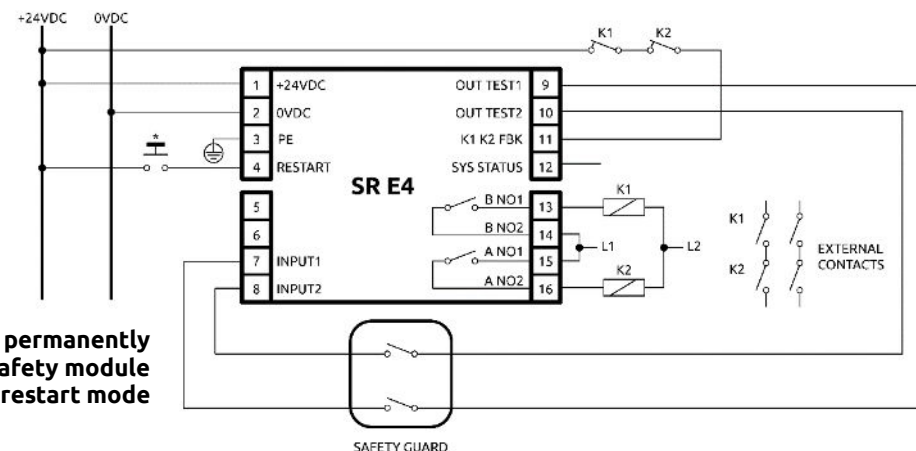



Figure 6

Example of connection of the SR E4 in MANUAL operation with K1 K2 relays and FBK K1 K2



* If the RESTART signal is permanently connected to 24VDC the safety module relay works in automatic restart mode

Figure 7

(I)	<p>⚠ Per installare e utilizzare in modo corretto e sicuro il modulo, è NECESSARIO consultare il manuale. ⚠ Consultare il manuale per il dettaglio dei cablaggi nei diversi modi di funzionamento. Altre condizioni o limitazioni d'uso sono presenti integralmente sul manuale. → I valori di sicurezza, i dati tecnici, le condizioni di garanzia e la Dichiarazione di Conformità sono contenute integralmente nel manuale.</p>	 MANUAL
(EN)	<p>⚠ To guarantee a correct and safe installation and operation of the module, it is NECESSARY to consult the user manual. ⚠ Refer to the manual for details of wiring in the different modes of operation. Other conditions or limitations for use are available in the manual. → The safety values, technical data, warranty conditions and Declaration of Conformity are fully contained in the manual.</p>	
(FR)	<p>⚠ Pour installer et utiliser correctement et en sécurité le module, il est NECESSAIRE de consulter le manuel d'instruction. ⚠ Consultez le manuel pour savoir comment s'effectue le câblage dans les différents modes de fonctionnement. D'autres conditions ou limitations d'utilisation figurent dans le manuel dans son intégralité. → Les valeurs de sécurité, caractéristiques techniques les conditions de garantie et la Déclaration de Conformité sont contenues dans le manuel dans leur intégralité.</p>	
(D)	<p>⚠ Um das Modul richtig und sicher zu installieren und zu verwenden, MÜSSEN Sie das Handbuch zu Rate ziehen. ⚠ Einzelheiten zur Verdrahtung in den verschiedenen Betriebsarten finden Sie im Handbuch. Weitere Bedingungen oder Einschränkungen für die Verwendung finden Sie im Handbuch. → Die Sicherheitswerte, Technische Daten, Garantiebedingungen und Konformitätserklärung sind vollständig im Handbuch enthalten.</p>	
(E)	<p>⚠ Para instalar y utilizar el módulo de forma correcta y segura, DEBE consultar el manual. ⚠ Consulte el manual para los detalles de cableado en los diferentes modos de operación. Otras condiciones o limitaciones de uso se encuentran en el manual en su totalidad. → Los valores de seguridad, datos técnicos, las condiciones de garantía y la Declaración de Conformidad se encuentran en el manual en su totalidad.</p>	